

BK-200AAP

STANDARD TYPE
AA SIZE (HR15/51)

N TYPE

DIMENSIONS (MM)

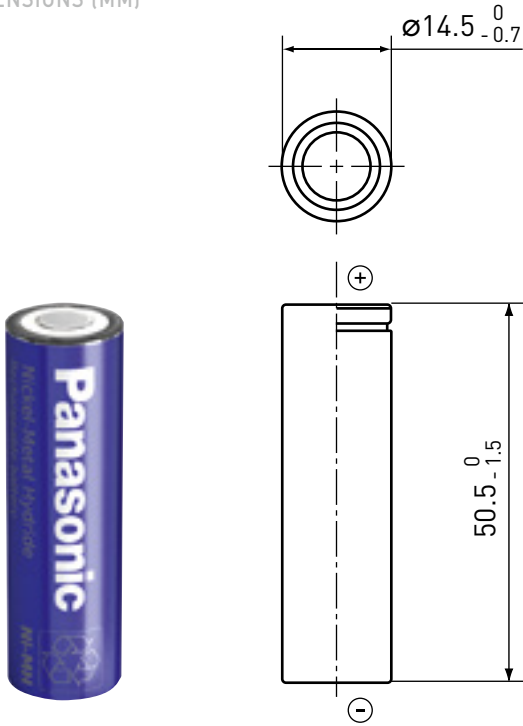

Specifications		BK-200AAP
Diameter (mm)		14.5 +0/-0.7
Total height (mm)		50.5 +0/-1.5
Approximate weight (g)		27
Nominal voltage (V)		1.2
Discharge capacity*1	Typical capacity*2 (mAh)	1,980
	Nominal capacity*3 (mAh)	1,900
Approx. internal impedance at 1,000Hz at charged state (mΩ)		20
Charge	Standard (mA x hrs.)	190 x 16
	Rapid*4 (mA x hrs.)	1,900 x 1.2
Charge (°C)	Standard	-10 to 60
	Rapid	-10 to 45
Discharge (°C)		-10 to 60
Ambient temperature	<1 year	-20 to 35
	<6 months	-20 to 45
	<1 month	-20 to 55
	<1 week	-20 to 65

*1 After charging at 0.1It for 16 hours, discharging at 0.2It.

*2 Average capacity (mAh). For reference only.

*3 Rated capacity (mAh).

*4 Need specially designed control system. Please contact Panasonic for details.

TYPICAL CHARGE CHARACTERISTICS

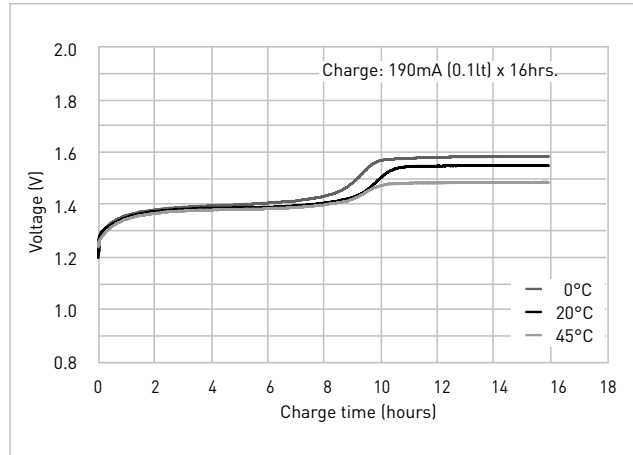

TYPICAL DISCHARGE CHARACTERISTICS

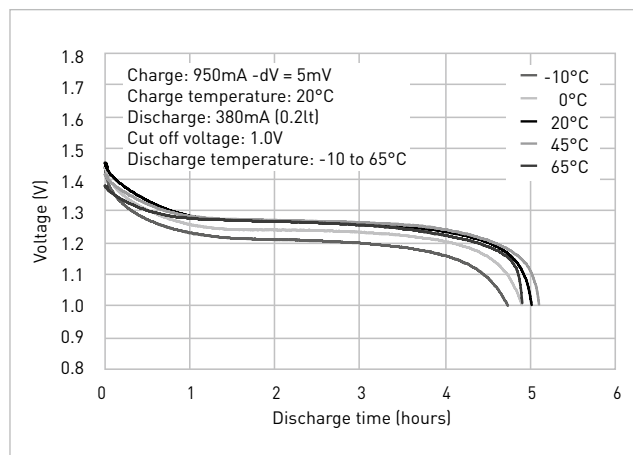
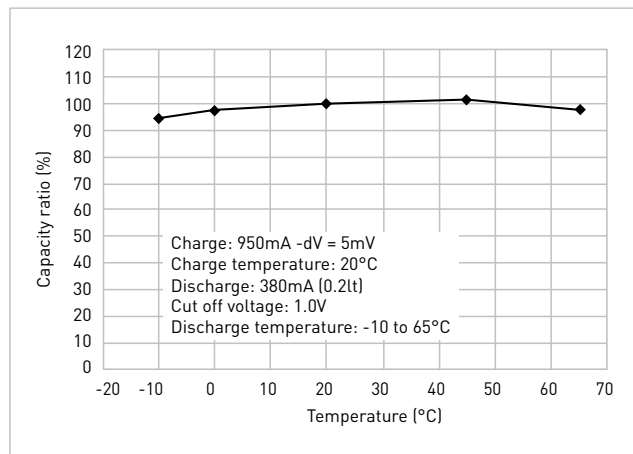

Battery performance and cycle life are strongly affected by how they are used. In order to maximise battery safety, please consult Panasonic when determining charge/discharge specs, warning label contents and design. The data in this document are for descriptive purposes only and are not intended to make or imply any guarantee or warranty.