

NEW BK-60AAAHU

HIGH TEMPERATURE & LONG LIFE TYPE
AAA SIZE (HR11/45)

H TYPE

DIMENSIONS (MM)

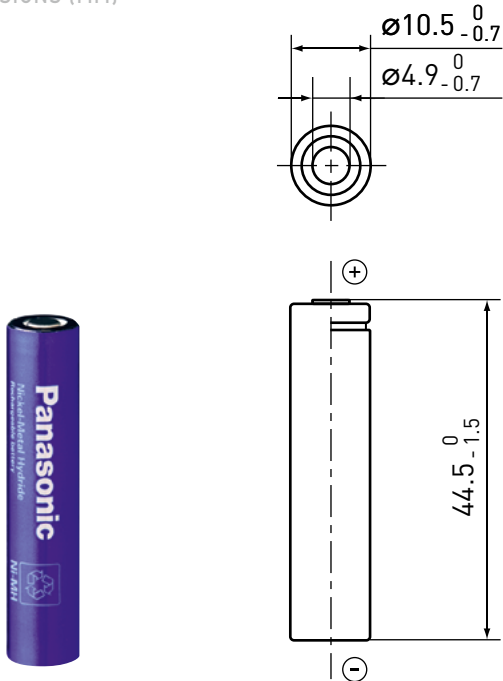

Specifications		BK-60AAAHU
Diameter (mm)		10.5 +0/-0.7
Total height (mm)		44.5 +0/-1.5
Approximate weight (g)		12
Nominal voltage (V)		1.2
Discharge capacity*1	Typical capacity*2 (mAh)	550
	Nominal capacity*3 (mAh)	500
Approx. internal impedance at 1,000Hz at charged state (mΩ)		35
Charge	Standard (mA x hrs.)	50 x 16
	Rapid*4 (mA x hrs.)	250 x 2.4
	Low rate (mA x hrs.)	25 x 32
Charge (°C)	Low rate	-20 to 75
	Standard	-20 to 75
	Rapid	-20 to 60
Discharge (°C)	Low rate	-20 to 75
	Standard	-20 to 75
	Rapid	-20 to 60
Storage (°C)	<1 year	-20 to 35
	<6 months	-20 to 45
	<1 month	-20 to 55
	<1 week	-20 to 65

TYPICAL CHARGE CHARACTERISTICS

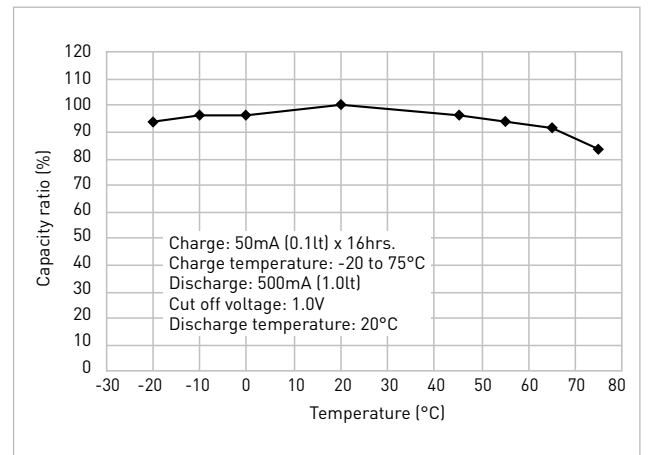
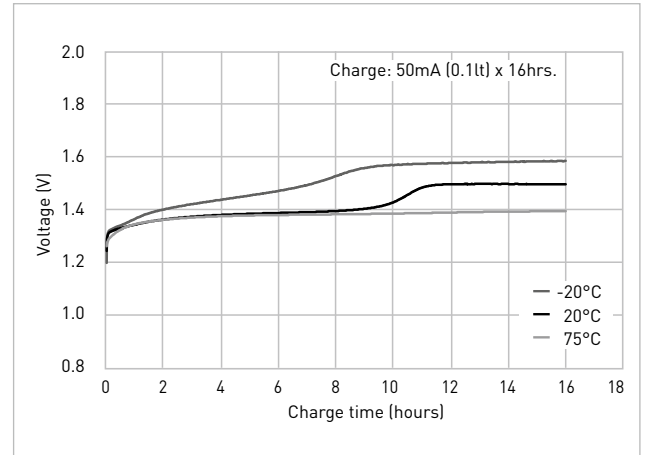

TYPICAL DISCHARGE CHARACTERISTICS

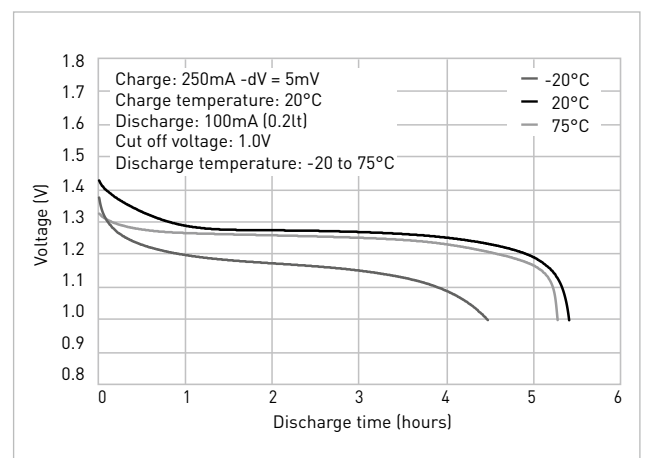

*1 After charging at 0.1It for 16 hours, discharging at 0.2It.
*2 Average capacity (mAh). For reference only.
*3 Rated capacity (mAh).
*4 Need specially designed control system. Please contact Panasonic for details.

Battery performance and cycle life are strongly affected by how they are used. In order to maximise battery safety, please consult Panasonic when determining charge/discharge specs, warning label contents and design. The data in this document are for descriptive purposes only and are not intended to make or imply any guarantee or warranty.