

3 MANGANESE RECHARGEABLE LITHIUM BATTERIES (ML SERIES)

ML-421

DIMENSIONS (MM)

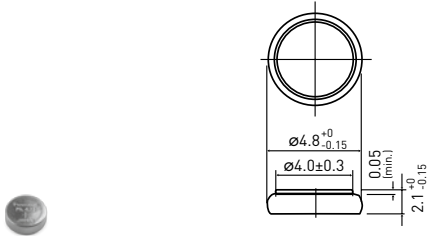

ML-614

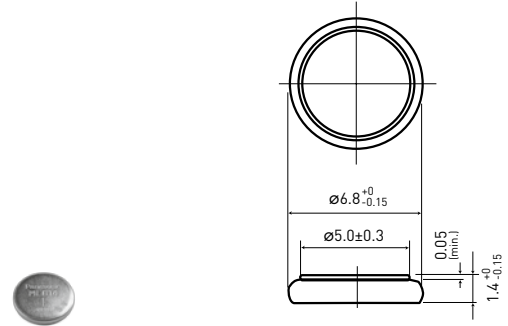

Model number	ML-421
Nominal voltage (V)	3
Nominal capacity (mAh)	2.3
Diameter (mm)	4.8
Total height (mm)	2.1
Discharging temperature range (°C)	-20 to +60
Weight (g)	0.1

Model number	ML-614
Nominal voltage (V)	3
Nominal capacity (mAh)	3.4
Diameter (mm)	6.8
Total height (mm)	1.4
Discharging temperature range (°C)	-20 to +60
Weight (g)	0.2

DISCHARGE CHARACTERISTICS

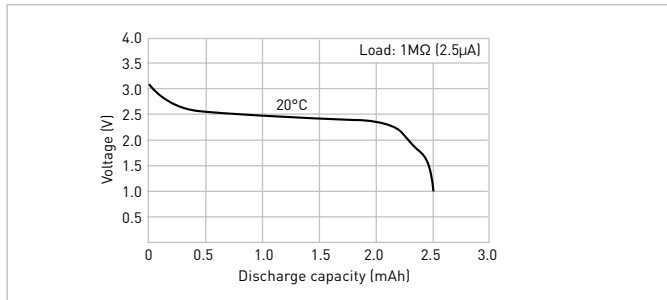

DISCHARGE CHARACTERISTICS

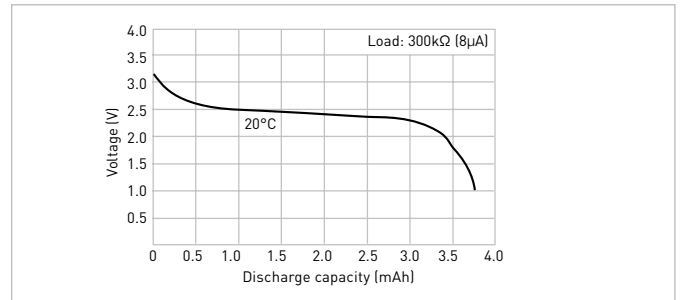

CHARGE VOLTAGE VS. DISCHARGE CAPACITY

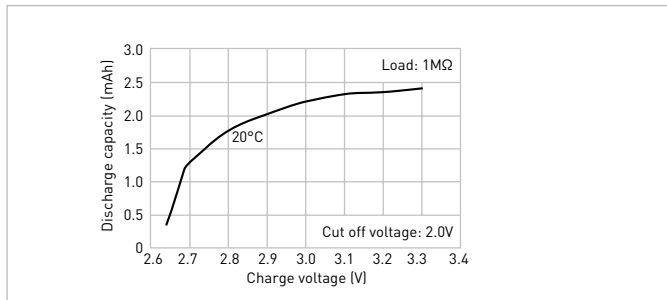

CONSUMPTION CURRENT VS. DURATION TIME

