

BK-250A

LOW TEMPERATURE TYPE  
A SIZE (HR17/50)

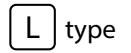

DIMENSIONS (MM)

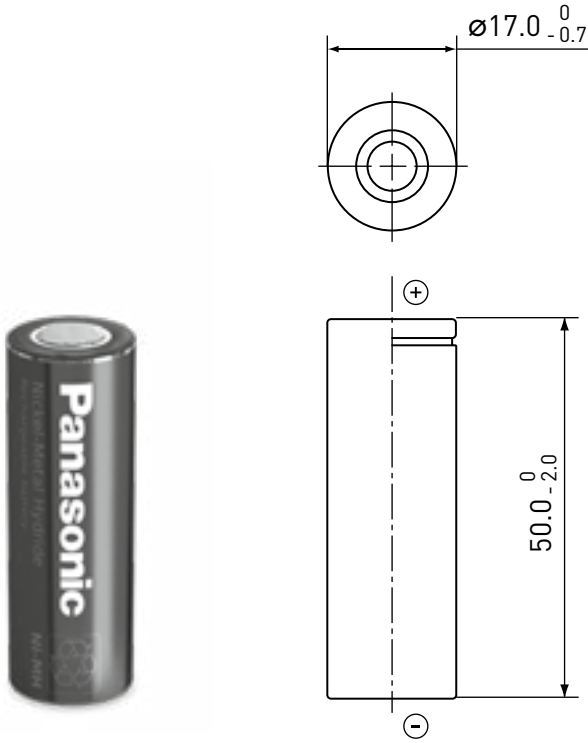

SPECIFICATIONS

Name		BK-250A	
Diameter (mm)		17.0 +0 / -0.7	
Height (mm)		50.0 +0 / -2.0	
Approximate weight (g)		40	
Nominal voltage (V)		1.2	
Discharge capacity*1	Average*2 (mAh)	2,600	
	Rated/min. (mAh)	2,450	
Approx. internal impedance at 1,000Hz at charged state (mΩ)		20	
Charge	Standard (mA x hrs.)	245 x 16	
	Rapid*3 (mA x hrs.)	2,450 x 1.2	
Ambient temperature	Charge	Standard (°C)	-10 to +45
		Rapid (°C)	0 to +40
Discharge (°C)		-30 to +65	
Storage	<1 year	-30 to +35	
	<6 months	-30 to +45	
	<1 month	-30 to +55	

\*1 After charging at 0.1It for 16 hours, discharging at 0.2It.  
 \*2 For reference only.  
 \*3 Need specially designed control system. Please contact Panasonic for details.

TYPICAL CHARGE CHARACTERISTICS

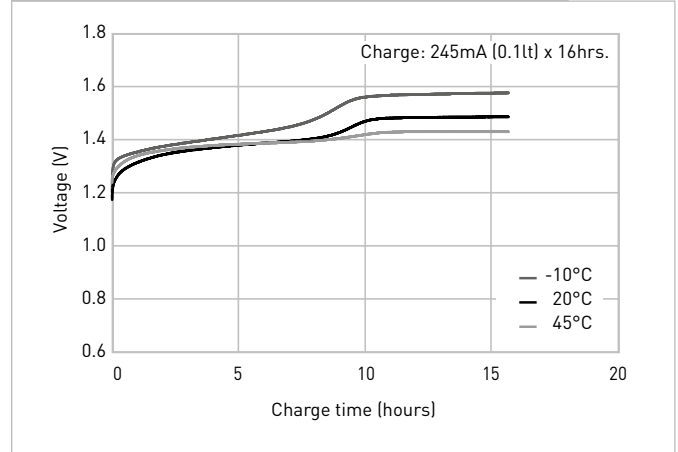

TYPICAL DISCHARGE CHARACTERISTICS

