

**BK-250SCH**  
HHR-250SCH (OLD)

HIGH RATE DISCHARGE & HIGH TEMPERATURE TYPE  
SC SIZE (HR23/43)

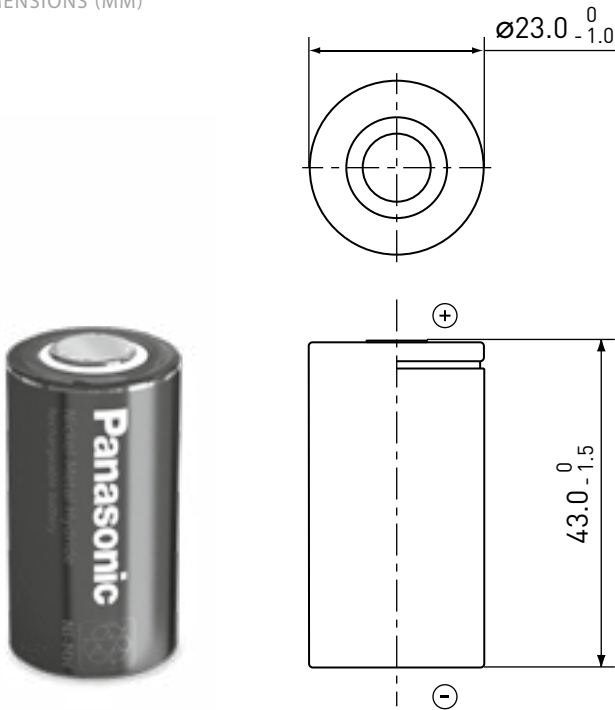

DIMENSIONS (MM)



SPECIFICATIONS

Name		BK-250SCH	
Diameter (mm)		23.0 +0/-1.0	
Height (mm)		43.0 +0/-1.5	
Approximate weight (g)		55	
Nominal voltage (V)		1.2	
Discharge capacity*1	Average*2 (mAh)	2,650	
	Rated/min. (mAh)	2,500	
Approx. internal impedance at 1,000Hz at charged state (mΩ)		5	
Charge	Standard (mA x hrs.)	250 x 16	
	Rapid*3 (mA x hrs.)	1,250 x 2.4	
	Low rate (mA x hrs.)		125 x 32
			83 x 48
Charge (°C)	Standard	-10 to +60	
	Rapid		
	Low rate	-10 to +45	
Discharge (°C)		-10 to +60	
Ambient temperature	Storage (°C)	<1 year	-20 to +35
		<6 months	-20 to +45
	<1 month	-20 to +55	
		<1 week	-20 to +65

TYPICAL CHARGE CHARACTERISTICS

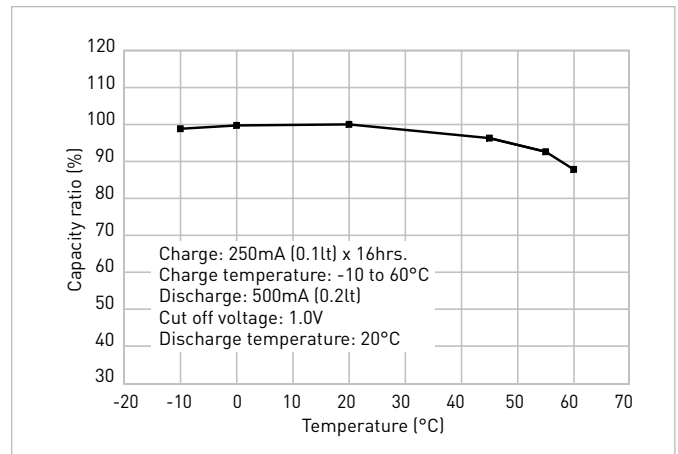
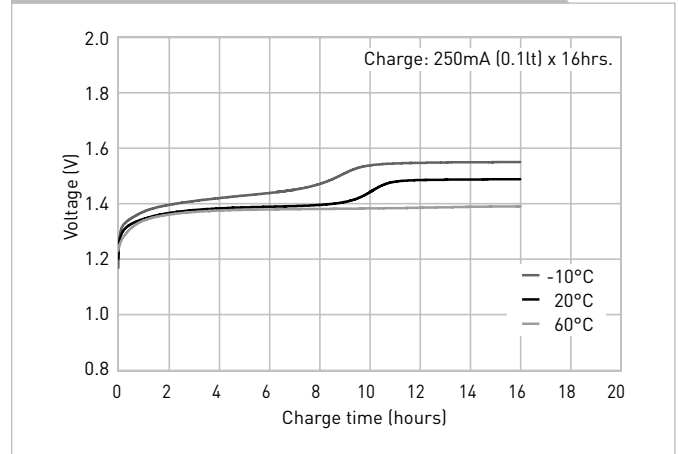

TYPICAL DISCHARGE CHARACTERISTICS

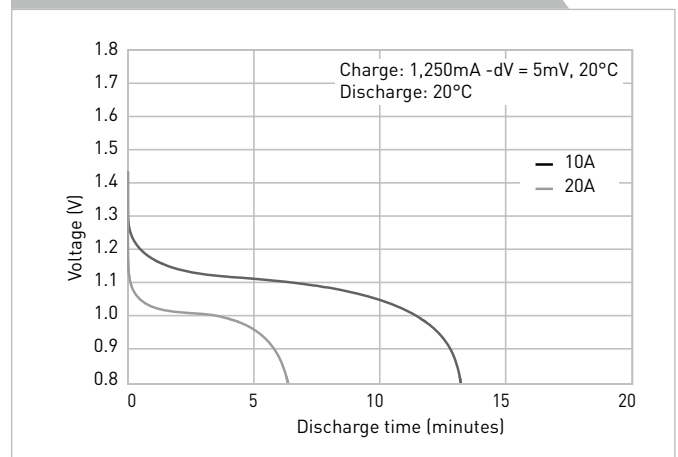

\*1 After charging at 0.1It for 16 hours, discharging at 0.2It.  
\*2 For reference only.  
\*3 Need specially designed control system. Please contact Panasonic for details.

Battery performance and cycle life are strongly affected by how they are used. In order to maximise battery safety, please consult Panasonic when determining charge/discharge specs, warning label contents and design. The data in this document are for descriptive purposes only and are not intended to make or imply any guarantee or warranty.