

BK-70AAH HHR-70AAH (OLD)

HIGH TEMPERATURE & LONG LIFE TYPE
AA SIZE (HR15/49)

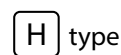

DIMENSIONS (MM)

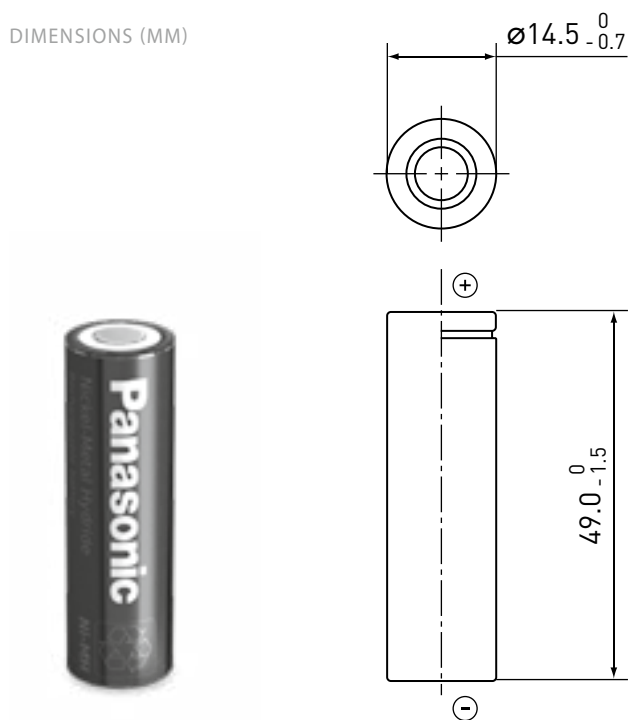

SPECIFICATIONS

Name		BK-70AAH	
Diameter (mm)		14.5 +0/-0.7	
Height (mm)		49.0 +0/-1.5	
Approximate weight (g)		18	
Nominal voltage (V)		1.2	
Discharge capacity*1	Average*2 (mAh)	750	
	Rated/min. (mAh)	700	
Approx. internal impedance at 1,000Hz at charged state (mΩ)		25	
Charge	Standard (mA x hrs.)	70 x 16	
	Rapid*3 (mA x hrs.)	350 x 2.4	
	Low rate (mA x hrs.)	35 x 32	
		23 x 48	
Charge (°C)	Standard	-10 to +60	
	Rapid		
	Low rate	-10 to +45	
Discharge (°C)		-10 to +60	
Ambient temperature	Storage (°C)	<1 year	-20 to +35
		<6 months	-20 to +45
	<1 month	-20 to +55	
	<1 week	-20 to +65	

*1 After charging at 0.1It for 16 hours, discharging at 0.2It.
*2 For reference only.
*3 Need specially designed control system. Please contact Panasonic for details.

TYPICAL CHARGE CHARACTERISTICS

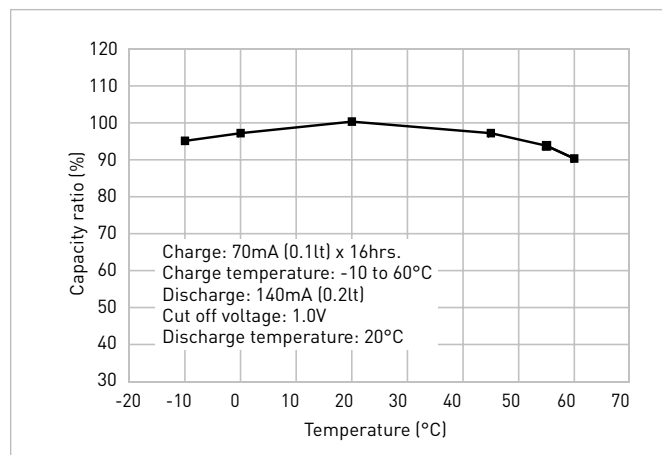
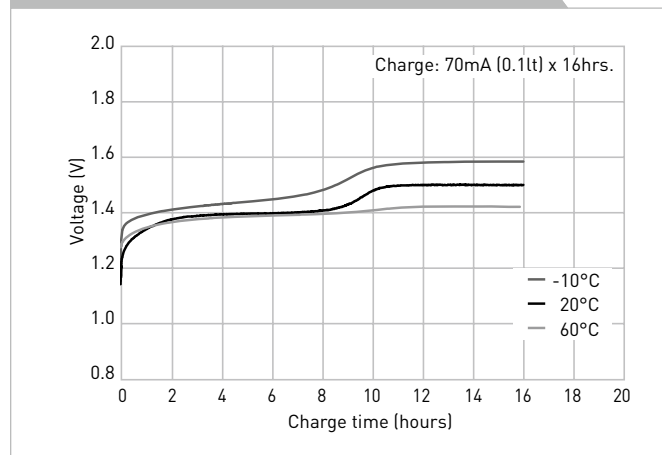

TYPICAL DISCHARGE CHARACTERISTICS

