

BK-110AAO
HHR-110AAO (OLD)

STANDARD TYPE
AA SIZE (HR15/51)

N type

DIMENSIONS (MM)

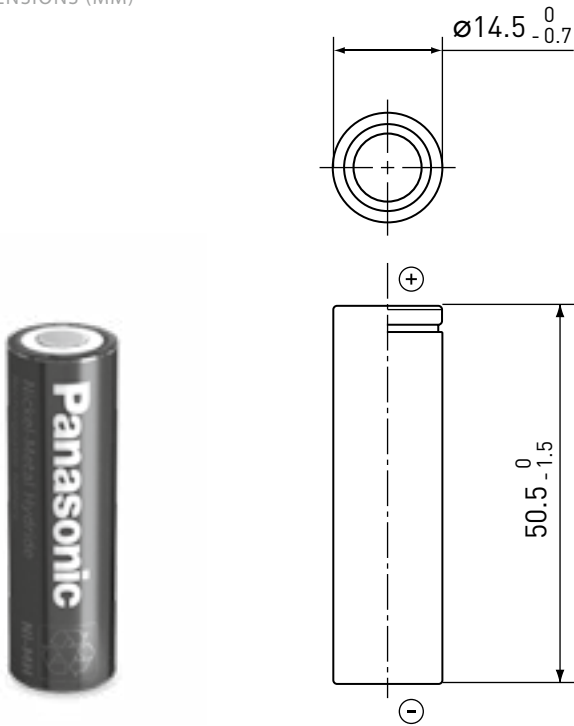

SPECIFICATIONS

Name		BK-110AAO
Diameter (mm)		14.5 +0/-0.7
Height (mm)		50.5 +0/-1.5
Approximate weight (g)		26
Nominal voltage (V)		1.2
Discharge capacity*1	Average*2 (mAh)	1,180
	Rated/min. (mAh)	1,100
Approx. internal impedance at 1,000Hz at charged state (mΩ)		16
Charge	Standard (mA x hrs.)	110 x 16
	Rapid*3 (mA x hrs.)	1,100 x 1.2
Charge	Standard (°C)	0 to +45
	Rapid (°C)	0 to +40
Discharge (°C)		-10 to +65
Storage	<1 year	-20 to +35
	<6 months	-20 to +45
	<1 month	-20 to +55
	<1 week	-20 to +65

TYPICAL CHARGE CHARACTERISTICS

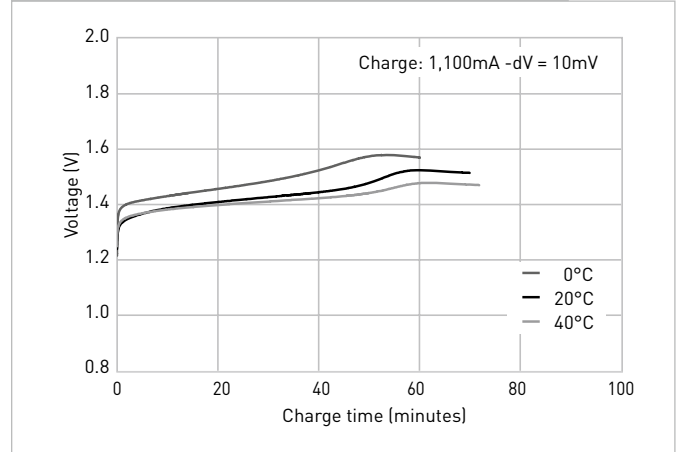

TYPICAL DISCHARGE CHARACTERISTICS

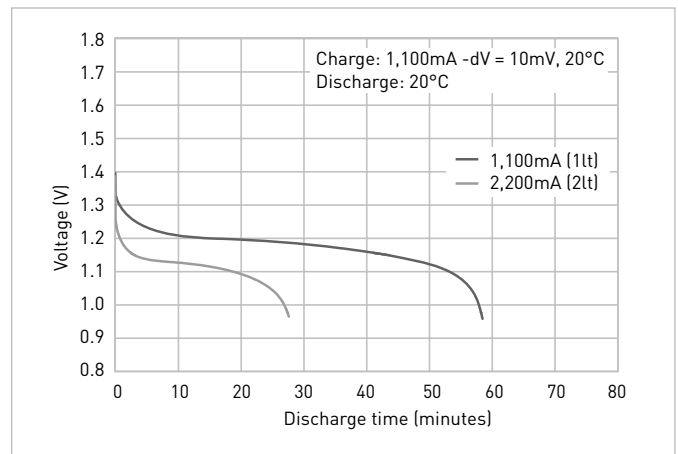
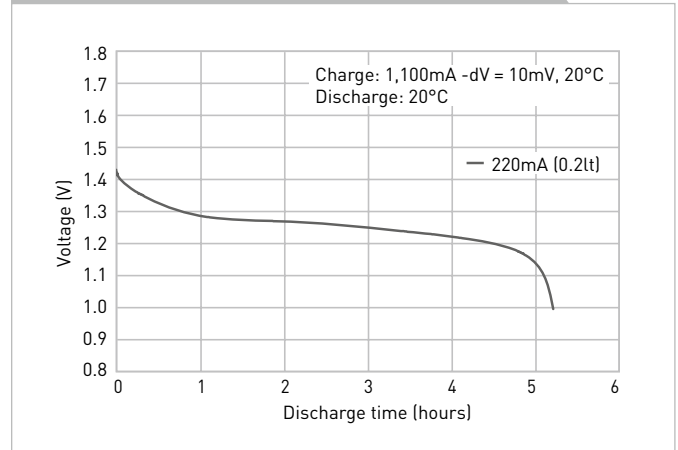

*1 After charging at 0.1It for 16 hours, discharging at 0.2It.
*2 For reference only.
*3 Need specially designed control system. Please contact Panasonic for details.