

BK-90AAA

STANDARD TYPE
L-AAA SIZE (HR11/67)

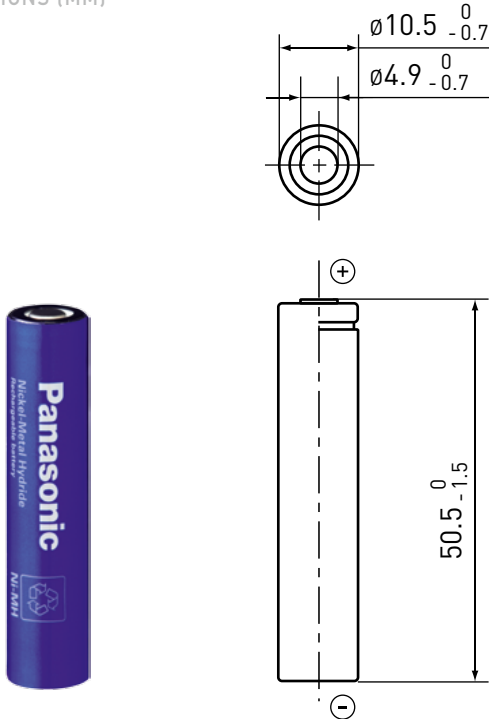

DIMENSIONS (MM)



Specifications		BK-90AAA
Diameter (mm)		10.5 +0/-0.7
Total height (mm)		50.5 +0/-1.5
Approximate weight (g)		14
Nominal voltage (V)		1.2
Discharge capacity*1	Typical capacity*2 (mAh)	880
	Nominal capacity*3 (mAh)	830
Approx. internal impedance at 1,000Hz at charged state (mΩ)		20
Charge	Standard (mA x hrs.)	83 x 16
	Rapid*4 (mA x hrs.)	830 x 1.2
Charge (°C)	Standard	0 to 45
	Rapid	0 to 40
Discharge (°C)		-10 to 65
Ambient temperature	<1 year	-20 to 35
	<6 months	-20 to 45
	<1 month	-20 to 55
	<1 week	-20 to 65

*1 After charging at 0.1It for 16 hours, discharging at 0.2It.
 *2 Average capacity (mAh). For reference only.
 *3 Rated capacity (mAh).
 *4 Need specially designed control system. Please contact Panasonic for details.

TYPICAL CHARGE CHARACTERISTICS

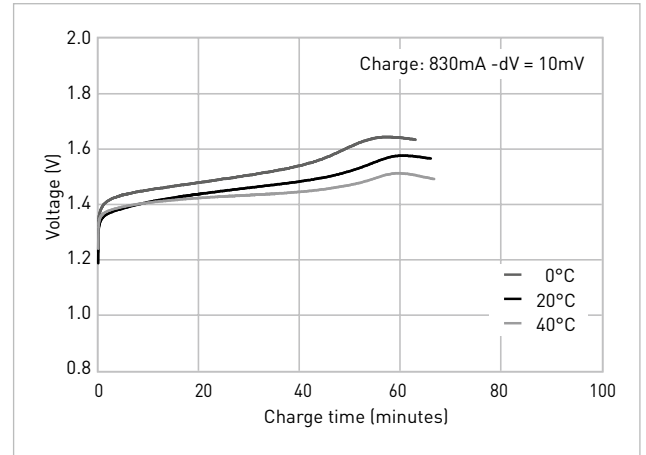

TYPICAL DISCHARGE CHARACTERISTICS

