

BK-90AAA

STANDARD TYPE  
L-AAA SIZE (HR11/67)

**N** type

DIMENSIONS (MM)

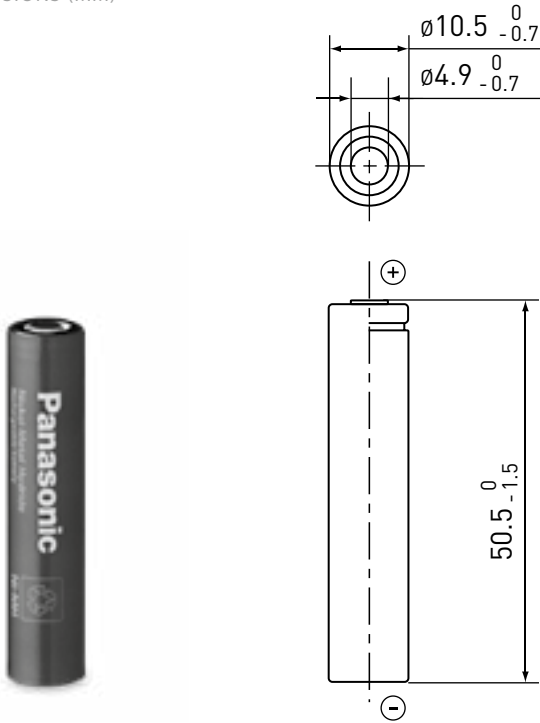

SPECIFICATIONS

Name		BK-90AAA
Diameter (mm)		10.5 +0/-0.7
Height (mm)		50.5 +0/-1.5
Approximate weight (g)		14
Nominal voltage (V)		1.2
Discharge capacity*1	Average*2 (mAh)	880
	Rated/min. (mAh)	830
Approx. internal impedance at 1,000Hz at charged state (mΩ)		20
Charge	Standard (mA x hrs.)	83 x 16
	Rapid*3 (mA x hrs.)	830 x 1.2
Charge	Standard (°C)	0 to +45
	Rapid (°C)	0 to +40
Discharge (°C)		-10 to +65
Storage	<1 year	-20 to +35
	<6 months	-20 to +45
	<1 month	-20 to +55
	<1 week	-20 to +65

TYPICAL CHARGE CHARACTERISTICS

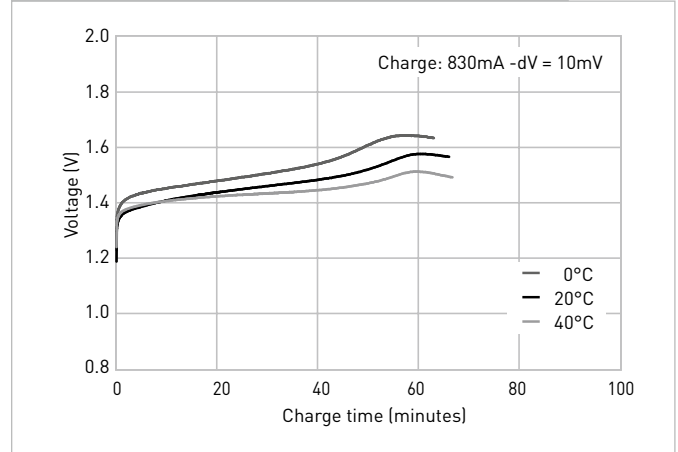

TYPICAL DISCHARGE CHARACTERISTICS

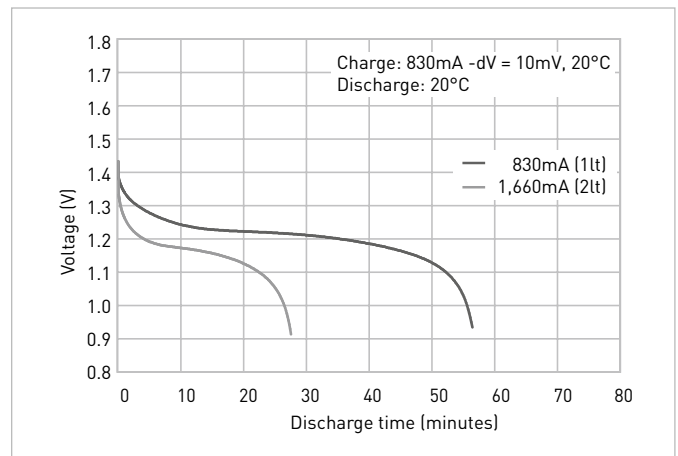
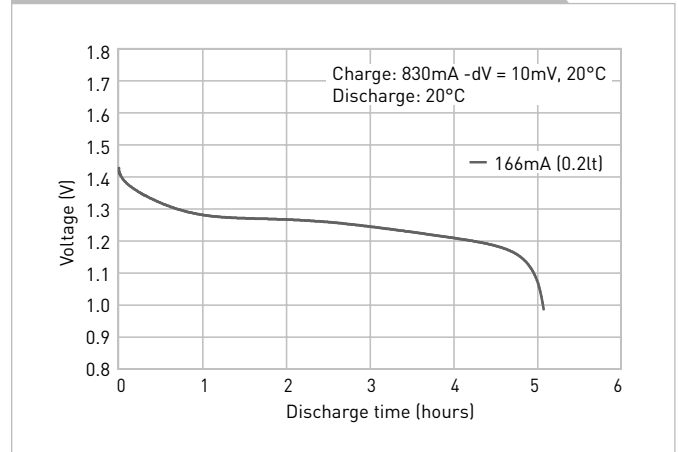

\*1 After charging at 0.1It for 16 hours, discharging at 0.2It.  
\*2 For reference only.  
\*3 Need specially designed control system. Please contact Panasonic for details.