

INDIVIDUAL DATA SHEETS

BK-80AAAB

HHR-80AAAB (OLD)

BUTTON TOP TYPE
AAA SIZE (HR11/45)

B TYPE

DIMENSIONS (MM)

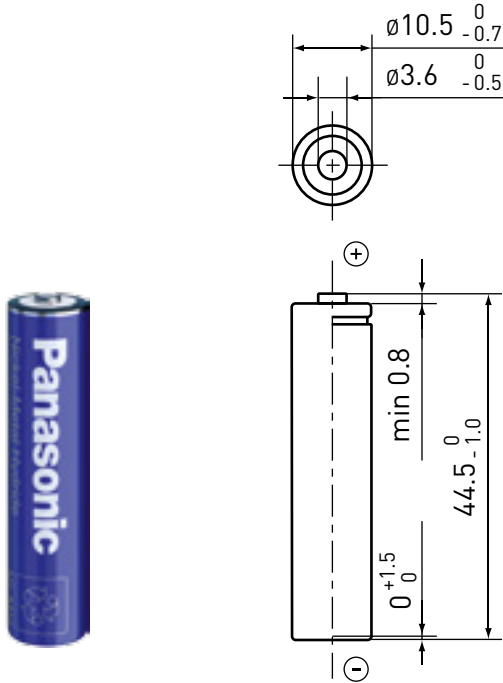

TYPICAL CHARGE CHARACTERISTICS

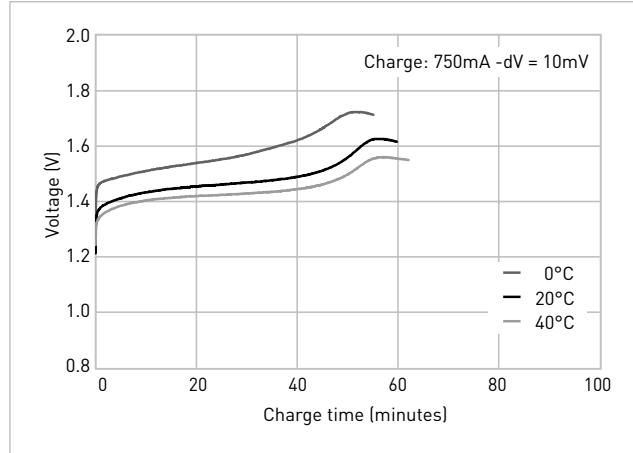

TYPICAL DISCHARGE CHARACTERISTICS

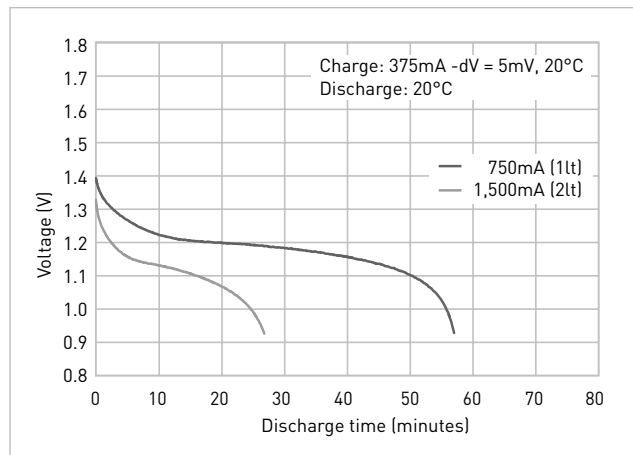
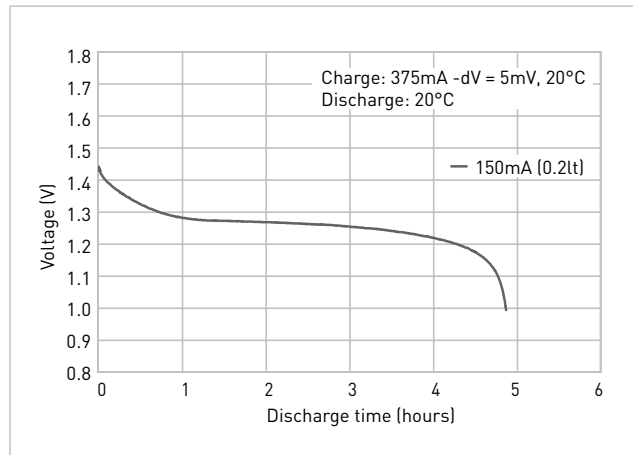

Specifications		BK-80AAAB
Diameter (mm)		10.5 +0/-0.7
Total height (mm)		44.5 +0/-1.0
Approximate weight (g)		13
Nominal voltage (V)		1.2
Discharge capacity*1	Typical capacity*2 (mAh)	780
	Nominal capacity*3 (mAh)	750
Approx. internal impedance at 1,000Hz at charged state (mΩ)		30
Charge	Standard (mA x hrs.)	75 x 16
	Rapid*4 (mA x hrs.)	750 x 1.2
Charge (°C)	Standard	0 to 45
	Rapid	0 to 40
Discharge (°C)		-10 to 65
Ambient temperature	<1 year	-20 to 35
	<6 months	-20 to 45
	<1 month	-20 to 55
	<1 week	-20 to 65

*1 After charging at 0.1It for 16 hours, discharging at 0.2It.

*2 Average capacity (mAh). For reference only.

*3 Rated capacity (mAh).

*4 Need specially designed control system. Please contact Panasonic for details.

Battery performance and cycle life are strongly affected by how they are used. In order to maximise battery safety, please consult Panasonic when determining charge/discharge specs, warning label contents and design. The data in this document are for descriptive purposes only and are not intended to make or imply any guarantee or warranty.