

UP-VW1236P

DIMENSIONS (MM)

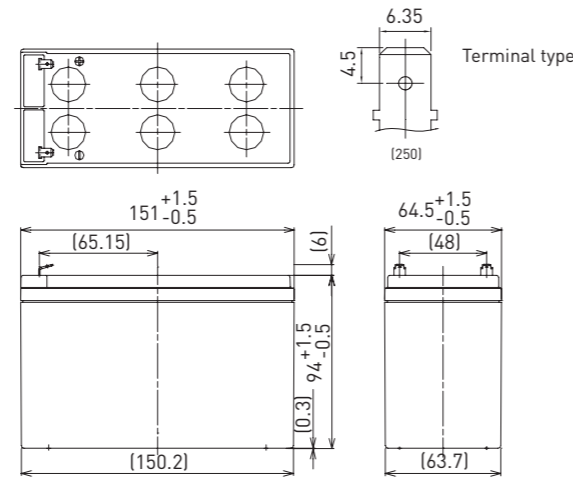

FOR STANDBY POWER SUPPLIES.
EXPECTED TRICKLE DESIGN LIFE: 6 - 9 YEARS AT 20°C
ACCORDING TO EUROBAT.



Contents indicated (including the recycle marking, etc.) are subject to change without notice.

Battery case resin: flame retardant (UL94 V-0)

SPECIFICATIONS

Name	UP-VW1236P1
Nominal voltage	12V
Rated power (cell@10MR)	36W
Dimensions	Length 151mm
	Width 64.5mm
	Height 100mm
Approx. mass	2.05kg
Terminal	Faston 250
Capacity (25°C)	30 minute rate 102W
	15 minute rate 169W
	10 minute rate 224W
	5 minute rate 348W
Impedance	Fully charged battery (25°C) 21mΩ
	40°C 102%
Temperature dependency of capacity (20 hour rate)	25°C 100%
	0°C 85%
	-15°C 65%
	After 3 month 91%
Self-discharge (25°C)	After 6 month 82%
	After 12 month 64%

DURATION OF DISCHARGE VS. DISCHARGE CURRENT

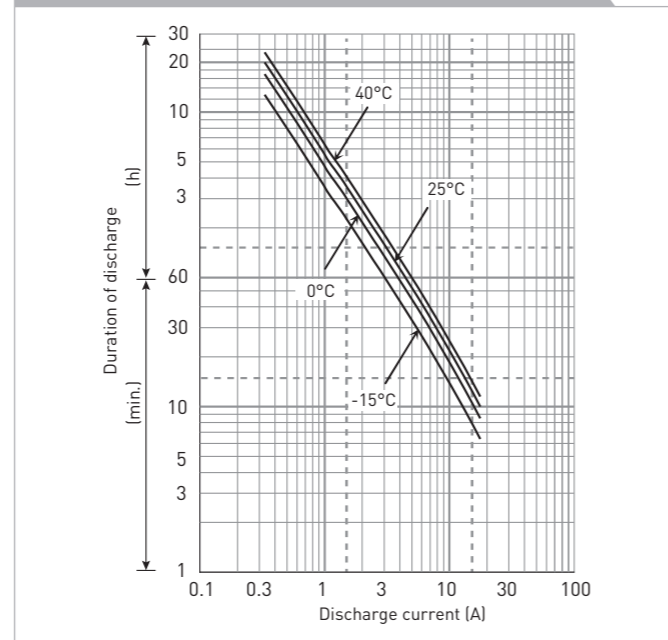

WATT TABLE (25°C)

Cut-off	3min.	5min.	10min.	15min.	20min.	30min.	45min.	1h	1.5h	2h	3h	4h	5h	6h	10h	20h
9.6V	461	348	224	169	140	102	73.3	58.3	44.1	34.5	24.3	18.6	15.1	12.7	7.60	4.02
9.9V	434	298	190	161	135	99.5	72.8	56.9	43.3	34.2	24.2	18.4	15.0	12.4	7.56	4.01
10.2V	406	283	185	153	131	97.4	69.8	55.3	41.0	32.3	23.1	18.1	14.4	12.1	7.24	3.87
10.5V	368	258	177	146	125	93.7	67.9	54.1	39.4	31.3	22.6	17.7	14.3	12.0	7.21	3.86
10.8V	331	232	167	140	120	90.1	63.6	50.0	36.8	27.9	21.0	16.4	13.1	11.1	6.72	3.61

AMPERE TABLE (25°C)

Cut-off	3min.	5min.	10min.	15min.	20min.	30min.	45min.	1h	1.5h	2h	3h	4h	5h	6h	10h	20h
9.6V	38.1	28.7	17.7	14.1	11.4	8.57	6.26	4.99	3.42	2.64	1.96	1.50	1.23	0.990	0.655	0.355
9.9V	35.9	27.4	17.3	13.4	11.0	8.39	6.22	4.85	3.35	2.62	1.95	1.49	1.22	0.986	0.652	0.354
10.2V	33.5	26.0	16.8	12.8	10.7	8.21	5.96	4.73	3.18	2.48	1.86	1.43	1.17	0.946	0.624	0.342
10.5V	30.4	23.7	16.0	12.2	10.23	7.91	5.80	4.63	3.05	2.40	1.82	1.37	1.10	0.936	0.622	0.330
10.8V	27.3	21.3	15.1	11.7	9.80	7.60	5.43	4.28	2.85	2.14	1.69	1.32	1.07	0.866	0.579	0.319

All mentioned values are average values

UP-VW1236P

CHARGING METHOD (25°C)

Trickle use Control voltage: 13.6V - 13.8V
Initial current: 0.930A or smaller

CUT-OFF VOLTAGE

Discharge current	0.310A - 1.24A	1.24A - 3.10A	3.10A - 6.20A	6.20A - 12.4A	12.4A - 18.6A
Cut-off voltage (V)	10.5	10.2	9.9	9.3	8.7

INFLUENCE OF TEMPERATURE ON TRICKLE LIFE

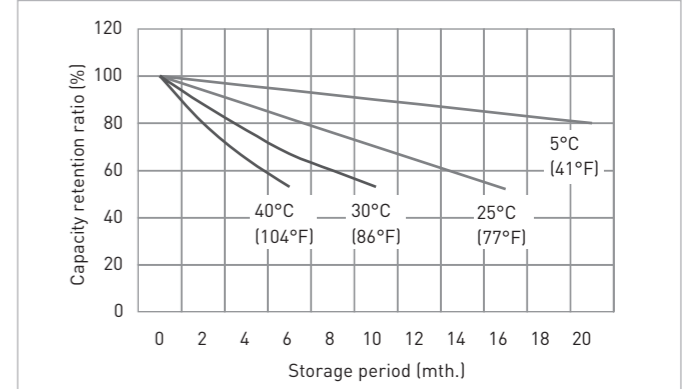
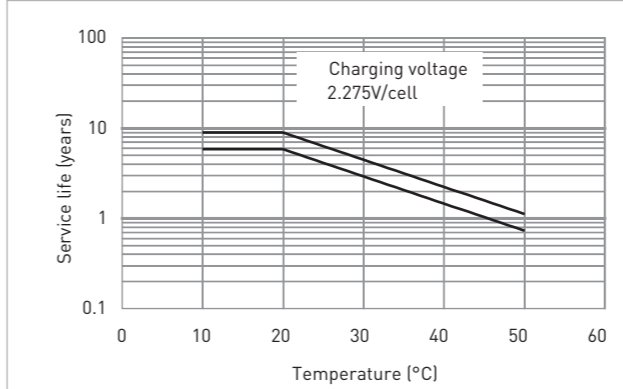

CONSTANT-VOLTAGE CONSTANT-CURRENT CHARGE CHARACTERISTICS FOR TRICKLE USE

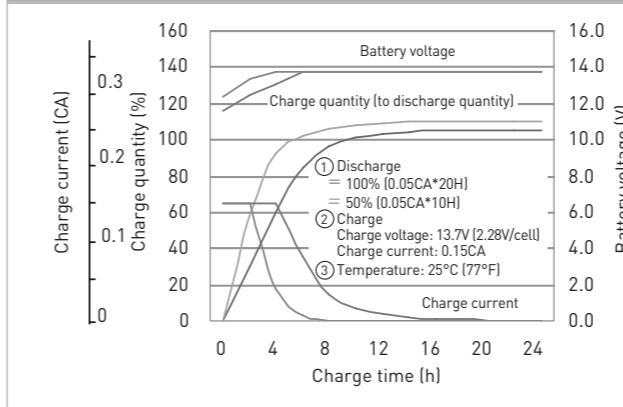

DISCHARGE CAPACITY BY TEMPERATURE AND BY DISCHARGE CURRENT

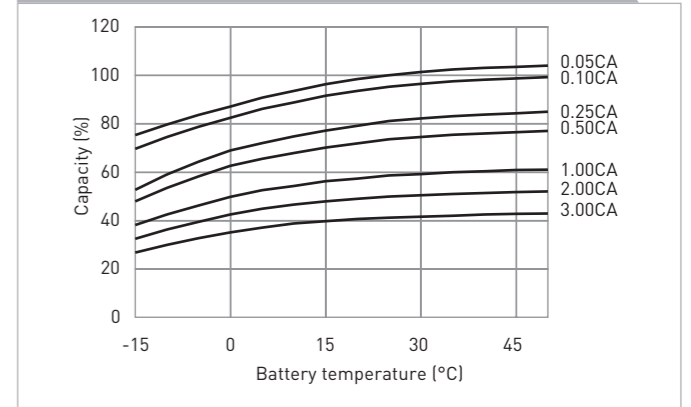

DISCHARGE CHARACTERISTICS

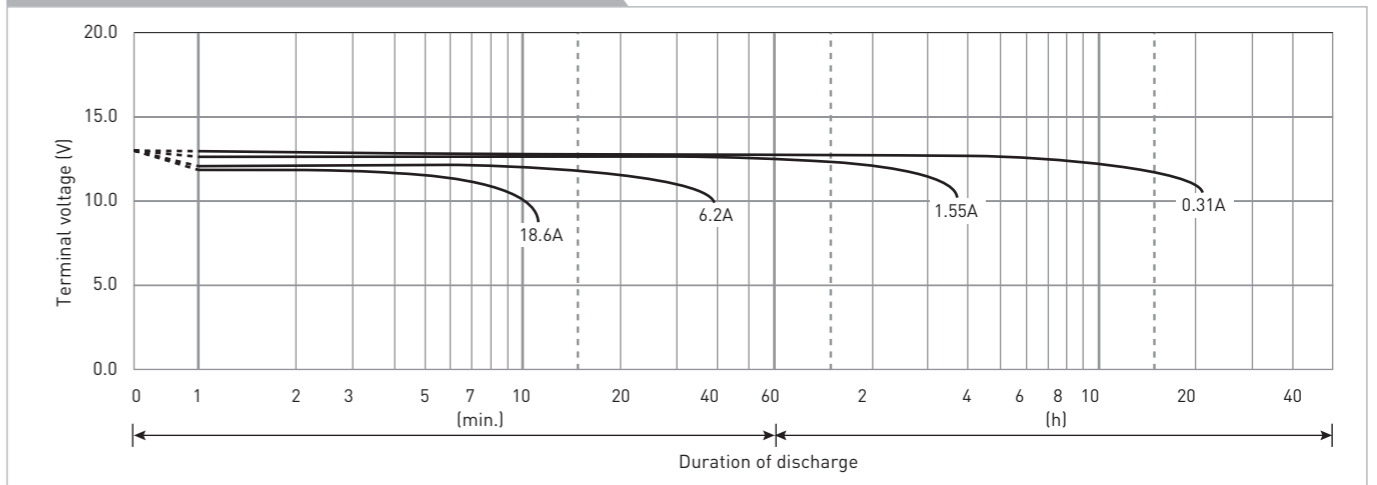

The data in this document are for descriptive purposes only and are not intended to make or imply any guarantee or warranty. Regarding handling and safety please consult our VRLA technical handbook chapter 1.