

LC-T12105P

DIMENSIONS (MM)



Contents indicated (including the recycle marking, etc.) are subject to change without notice.

FOR ENERGY STORAGE APPLICATIONS.
CYCLE LONG-LIFE TYPE

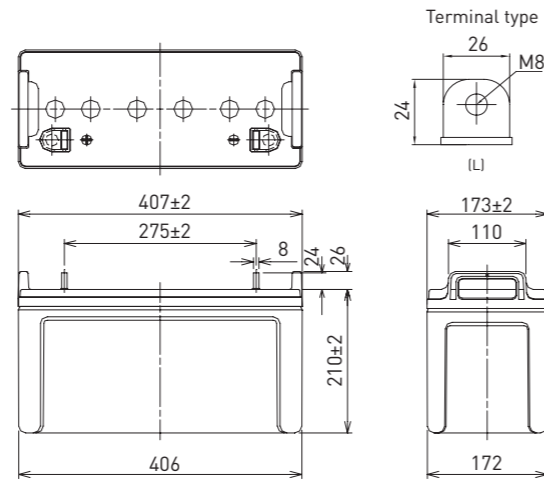

Battery case resin: standard (UL94 HB)

SPECIFICATIONS

Name	LC-T12105P	
Nominal voltage	12V	
Nominal capacity (20 hour rate)	105Ah	
Dimensions	Length	407mm
	Width	173mm
	Height	236mm
Approx. mass	34.0kg	
Terminal	M8 bolt/nut	
Capacity (25°C)	20 hour rate	105Ah
	10 hour rate	101Ah
	3 hour rate	84Ah
	1 hour rate	70Ah
Impedance	Fully charged battery (25°C)	5mΩ
	40°C	102%
Temperature dependency of capacity (20 hour rate)	25°C	100%
	0°C	85%
	-15°C	65%
	Self-discharge (25°C)	After 3 month
	After 6 month	82%
	After 12 month	64%

DURATION OF DISCHARGE VS. DISCHARGE CURRENT

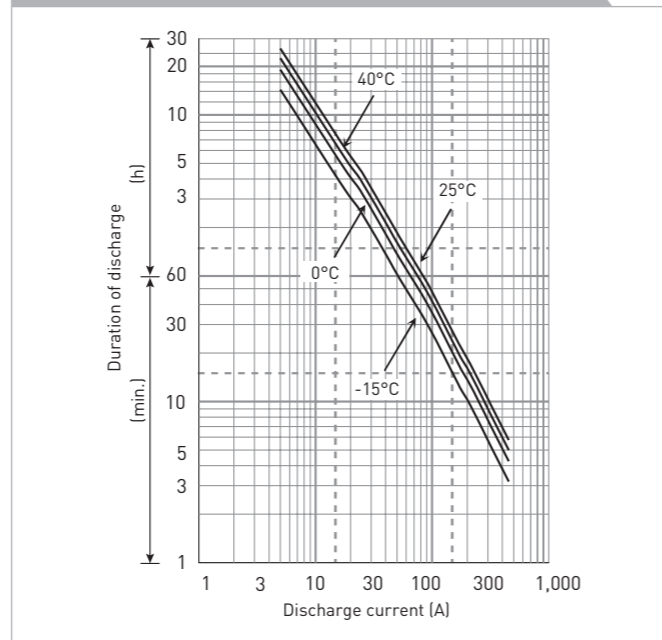

WATT TABLE (25°C)

Cut-off	[Wattage/battery]														
	5min.	10min.	15min.	20min.	30min.	45min.	1h	1.5h	2h	3h	4h	5h	6h	10h	20h
9.6V	3,400	2,600	2,300	1,949	1,710	1,136	1,005.7	897.9	748.3	354.0	316.1	279.7	248.4	133.94	68.17
9.9V	3,301	2,524	2,233	1,892	1,660	1,103	976.4	871.8	726.5	343.7	306.9	271.6	241.2	130.03	66.19
10.2V	3,205	2,451	2,168	1,837	1,612	1,071	948.0	846.4	705.3	333.7	298.0	263.7	234.2	126.25	64.89
10.5V	3,111	2,379	2,105	1,784	1,565	1,040	920.4	821.7	684.8	324.0	289.3	256.0	227.4	122.57	63.00
10.8V	3,021	2,310	2,044	1,732	1,519	1,010	893.5	797.8	664.8	314.6	280.9	248.5	220.7	119.00	61.17

AMPERE TABLE (25°C)

Cut-off	[Ampere/battery]														
	5min.	10min.	15min.	20min.	30min.	45min.	1h	1.5h	2h	3h	4h	5h	6h	10h	20h
9.6V	350	270	215	172	137	96	75.8	60.2	47.7	29.7	23.6	18.7	14.9	10.30	5.38
9.9V	340	262	209	167	133	94	73.6	58.4	46.4	29.1	22.9	18.2	14.4	10.15	5.28
10.2V	330	255	203	162	129	92	71.4	56.7	45.0	28.6	22.2	17.6	14.0	10.20	5.26
10.5V	320	247	197	157	125	90	70.0	55.1	43.7	28.0	21.6	17.1	13.6	10.10	5.25
10.8V	311	240	191	153	121	88	68.6	53.5	42.4	27.5	21.0	16.6	13.2	10.00	5.17

All mentioned values are average values

LC-T12105P

CHARGING METHOD (25°C)

Cycle use
Control voltage: 14.5V - 14.9V
Initial current: 42.0A or smaller

CUT-OFF VOLTAGE

Discharge current	5.25A - 21.0A	21.0A - 52.50A	52.5A - 105A	105A - 210A	210A - 315A
Cut-off voltage	10.5V	10.2V	9.9V	9.3V	8.7V

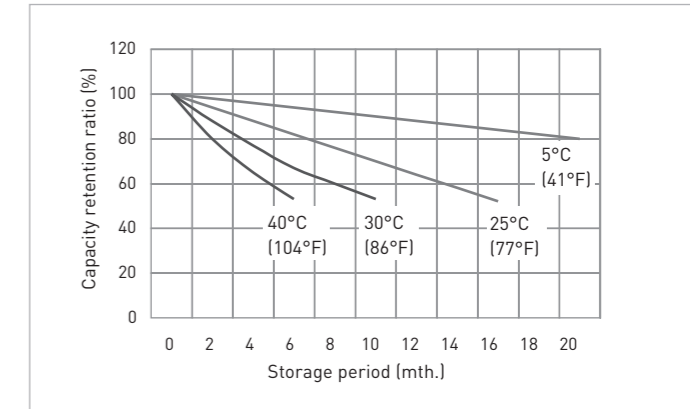
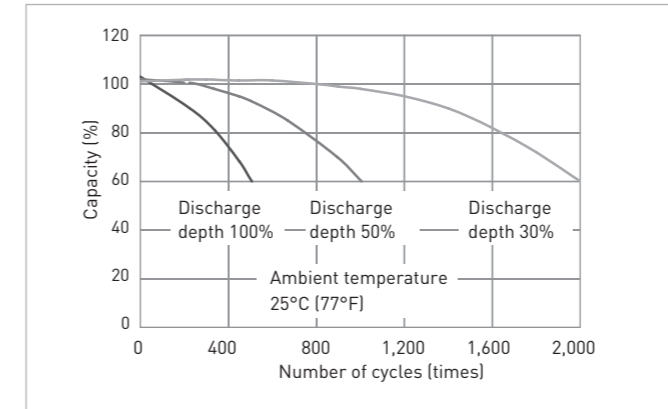

CONSTANT-VOLTAGE CONSTANT-CURRENT CHARGE CHARACTERISTICS FOR CYCLE USE

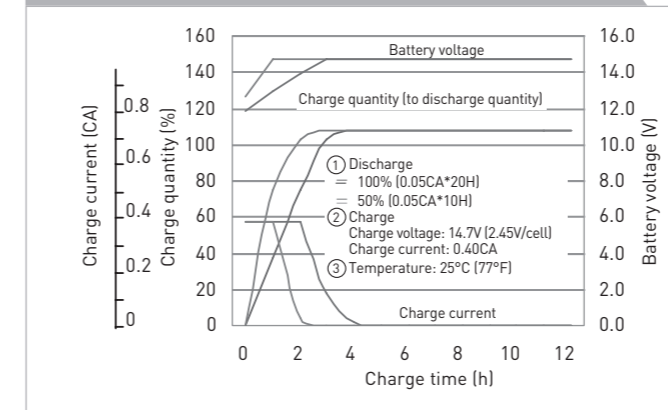

DISCHARGE CAPACITY BY TEMPERATURE AND BY DISCHARGE CURRENT

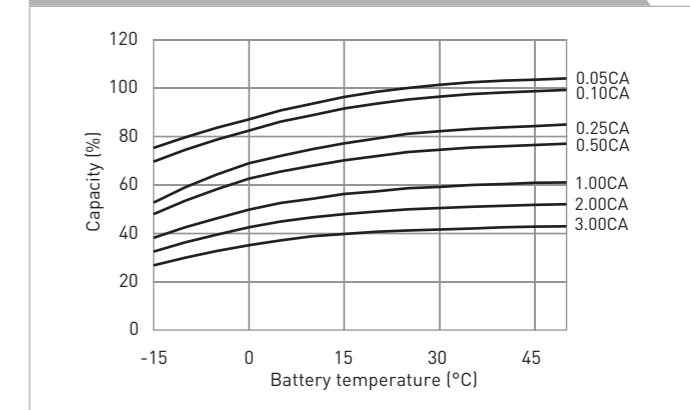

DISCHARGE CHARACTERISTICS

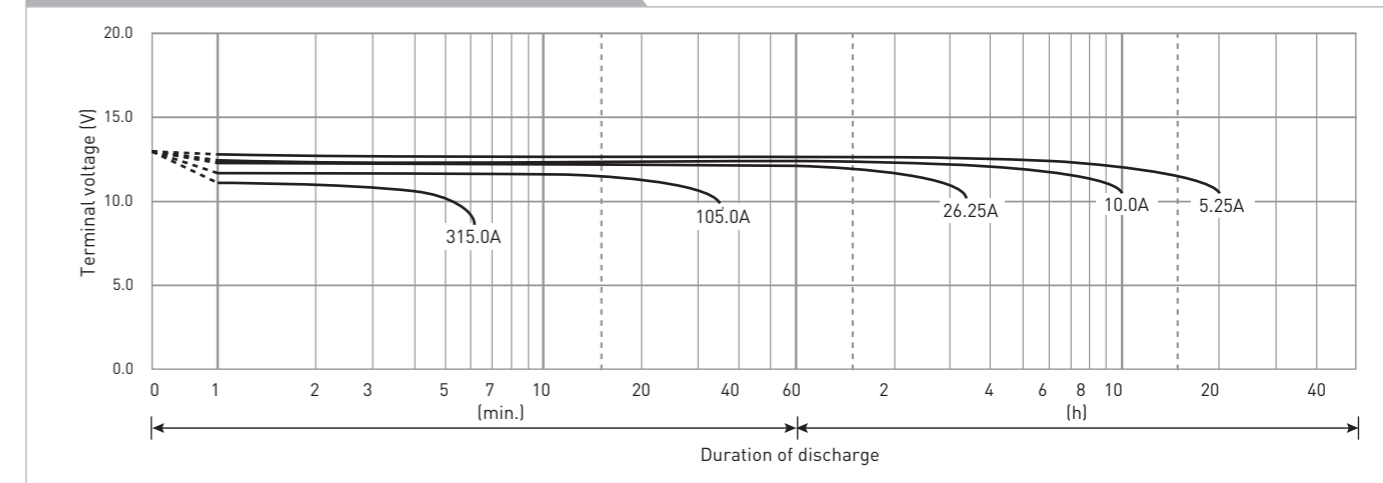

The data in this document are for descriptive purposes only and are not intended to make or imply any guarantee or warranty. Regarding handling and safety please consult our VRLA technical handbook chapter 1.