

SUPER HEAVY DUTY BATTERY

Document Title: PB0210460

3R12

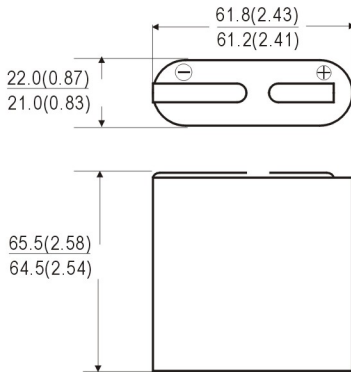

Chemical System : Zinc -Manganese Dioxide
(Zinc Chloride Electrolyte)

Camelion No. : 3R12P

IEC No. : 3R12

ANSI/NEDA No. : 3R12

Average Weight : 110.1g

Dimension(L x W x H) : $61.5^{+0.3} \times 21.5^{+0.5} \times 65.0^{+0.5}$ mm
 $2.42^{+0.01} \times 0.85^{+0.02} \times 2.56^{+0.02}$ inch

Terminals : Flat

Nominal Voltage : 4.5Volts

Average Capacity : 2000mAh to 2.7 volts
($20 \pm 2^\circ\text{C}$, Rated capacity at 25 mA continuous drain)

Jacket : Paper

Unit: mm(inch)

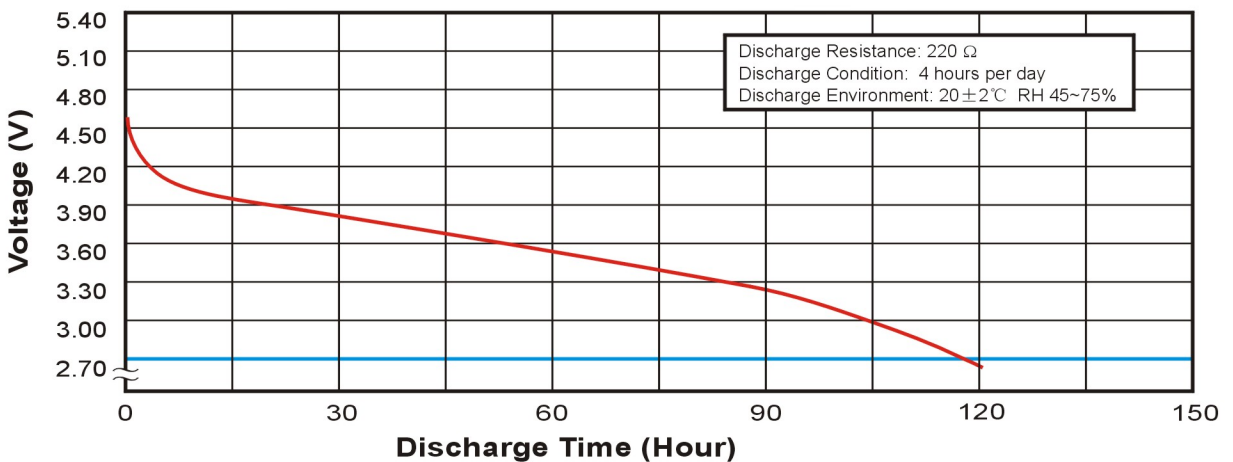
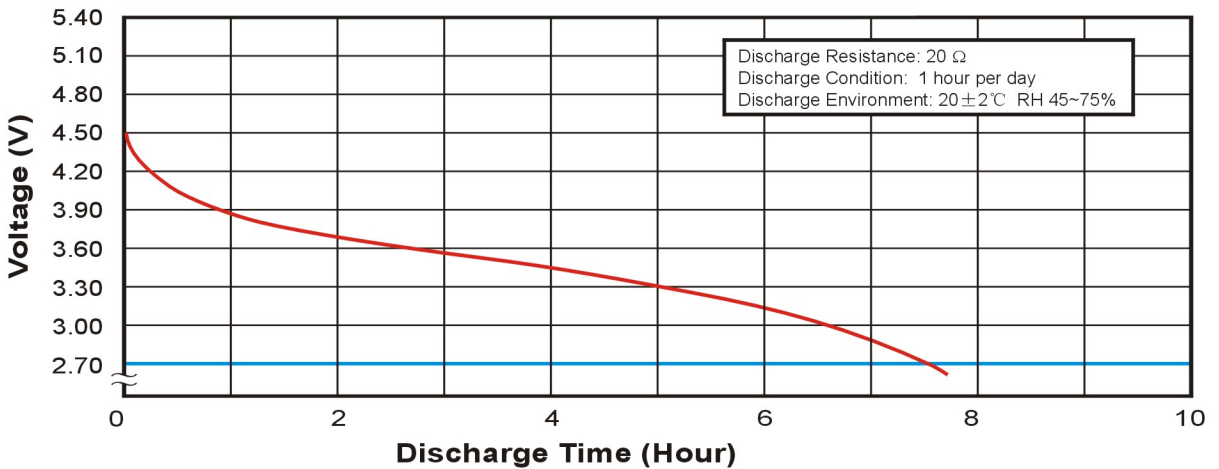

Notice:

Environmental elements comply with RoHS requirements. This information is subject to change without prior notice and for reference only. It should not be used as a basis for a product guarantee or warranty. For additional information, please consult your nearest Camelion Sales Office or Distributor or visit our website at: www.camelionbattery.com.