

## PLUS ALKALINE BATTERY

# 3LR12

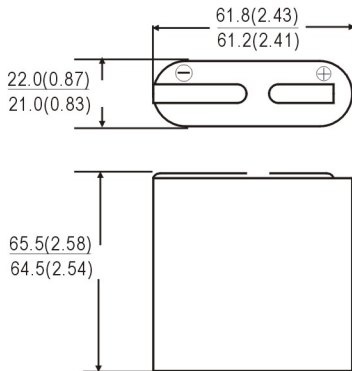

**Chemical System :** Alkaline

Zinc-Manganese Dioxide (Zn/MnO<sub>2</sub>)

**Camelion Model :** 3LR12

**IEC No. :** 3LR12

**ANSI/NEDA No. :** 3LR12

**Average Weight :** 83.0g

**Dimension (L x W x H) :** 61.5<sup>+0.3</sup> x 21.5<sup>+0.5</sup> x 65.0<sup>+0.5</sup> mm  
2.42<sup>+0.01</sup> x 0.85<sup>+0.02</sup> x 2.56<sup>+0.02</sup> inch

**Terminals :** Flat

**Nominal Voltage :** 4.5Volts

**Average Capacity :** about 3000mAh to 2.7 volts  
(20 ± 2°C, Rated capacity at 25 mA continuous drain)

**Jacket :** Paper Label

Unit: mm(inch)

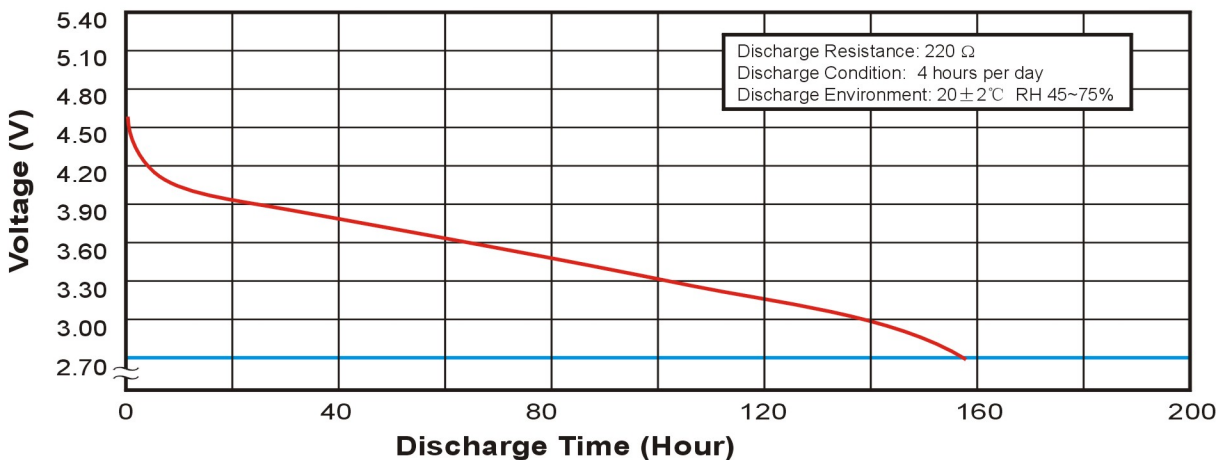
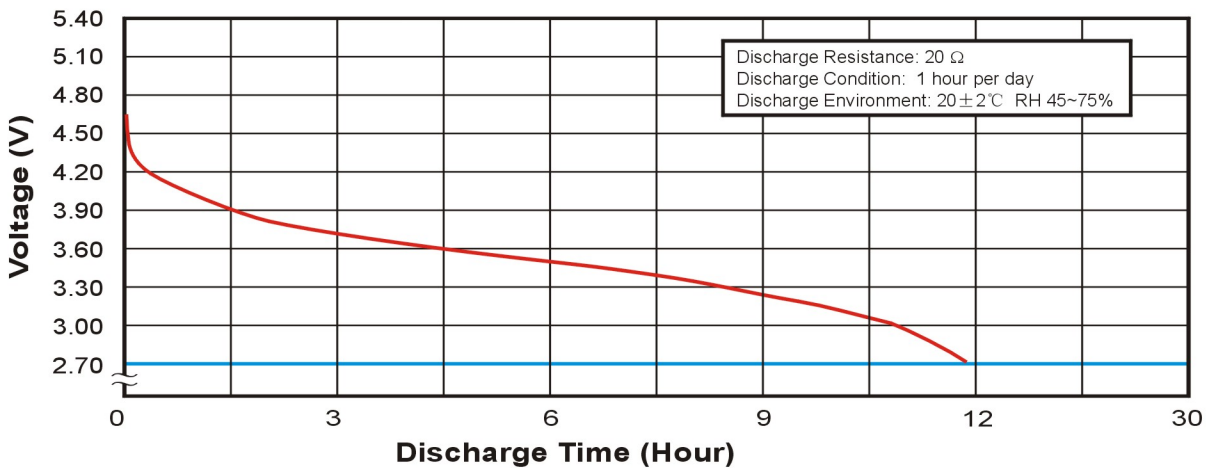

**Notice:**

Environmental elements comply with RoHS requirements. This information is subject to change without prior notice and for reference only. It should not be used as a basis for a product guarantee or warranty. For additional information, please consult your nearest Camelion Sales Office or Distributor or visit our website at: [www.camelionbattery.com](http://www.camelionbattery.com).